

QUOTE REQUEST FORM

Drilling Tool—Solid Carbide or PCD (Diamond)



Customer Information

Company Name _____ Project# _____ Date _____

Phone Number _____ Email _____

Quantity Needed _____ Annual Usage (if blanket order): _____

Tell Us About Your Application

Workpiece

Material _____

If Composite material, please fill in below:

Layers	Thickness	Material
Top		
Core		
Bottom		
Other		

Machine Information

Brand _____

Machine Type _____

Feed (select one): Mechanical Manual

Max Feed Rate _____

Max RPM _____

Clamping System _____

Tool Body

Tool Dimensions	
L	
L2	
L3	
SL	
S	
D	
L4 max	

- Internal Cooling
- RH Rotation
- LH Rotation
- Solid Carbide
- PCD Tipped
- PCD Coated

_____ Drill Depth
 _____ Hole Tolerance

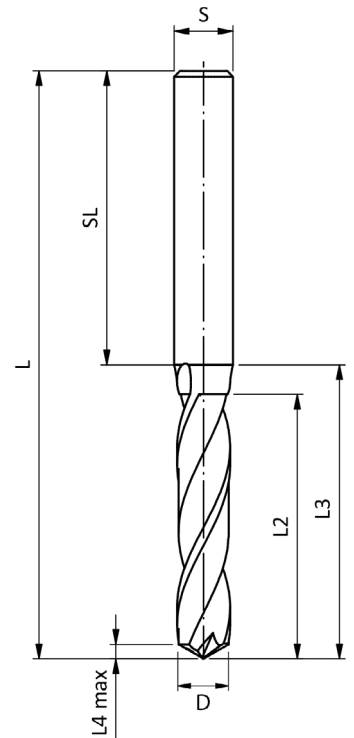

Cutting Detail

- Blind Hole
- Through Hole

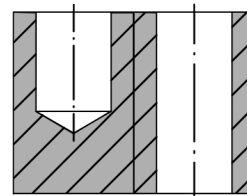

DO YOU HAVE A TOOL DRAWING OR SKETCH?

Email us at sales@gdptooling.com